



SPM

“Crafting Excellence From 2013”



About Us

SPM Hydraulics is expert in engineering and manufacturing Hydraulic Cylinders & Hydraulic Power Units. We have vision as well as ability to produce hydraulic cylinder from small to large in diameter with extra-long stroke. Our facility has been updated constantly over the years - adding not only newer equipment, but intentionally expanding our capabilities to promote quicker turn around times for our customers.

Manufacturing Capacity

SPM Hydraulics having manufacturing facility with high level precision machinery with wide range of sizes and various machining process like CNC Turning 5 MM TO 450 MM diameter. VMC machining up to 1000 MM length and 600 MM width & 600 MM height as well proof turning from 30 MM to 900 MM diameter. We have in house honing machine with max diameter capacity of 400 MM and length up to 2000 MM. Further more we have in-house welding facility with multiple type of welding machine for the assembly of parts. All the parts can be manufactured with at least tolerance of 10 microns with surface finish of 0.1 to 0.8 microns with honing burnishing and grinding processes.

Inspection

For Unmatched performance, extended life cycle with safe and well reliable lifting we believe quality as DNA of whole manufacturing process so we have wide range and multiple methods of inspection as well testing facilities from raw material to finished goods. Our team ensures that each part is master piece of work and done as its finest level. We have in house testing facility for hydraulic cylinder with maximum test pressure 450 bars and we check each and every cylinder before supply.

Paint

Paint gives corrosion protection, aesthetic appearance, identification and safety which acts as barrier between metal surface of the cylinder and environmental elements. Our standard paint options include acrylic primer & enamel while specific paints available on customers' demand.

Legacy Of Decade Experience

A company with a decade of experience likely has honed its skills and expertise in designing and manufacturing hydraulic cylinders, ensuring a high level of proficiency. SPM hydraulics have capacity as large as their vision. Each product meets or exceeds the necessary compliance requirements. There are many reasons which differ us from another segment for same services Like International presence, On time delivery, Proven track record, Customisation capability Etc.

Design

This process in hydraulics play crucial role as it directly influences their performance, efficiency & Durability in tough or crucial. SPM Hydraulics have a team that combines practical knowledge and technical expertise with computer aided technics. Our robust and tailored design which having high agility for easy adaption as well match with your needs at finest. We develop design for its maximum technical advantage & better performance, minimum energy loss & maintenance. Our sealing methods are followed by global seal fitting instruction method. We use seals only from standard companies like Parker, Kastas, Gapi, Halite, Technolan, Freudenburg, Trelleborg, Spearage, Etc. Assembling is last and most important operation of cylinders which conduct in neat and dry area.

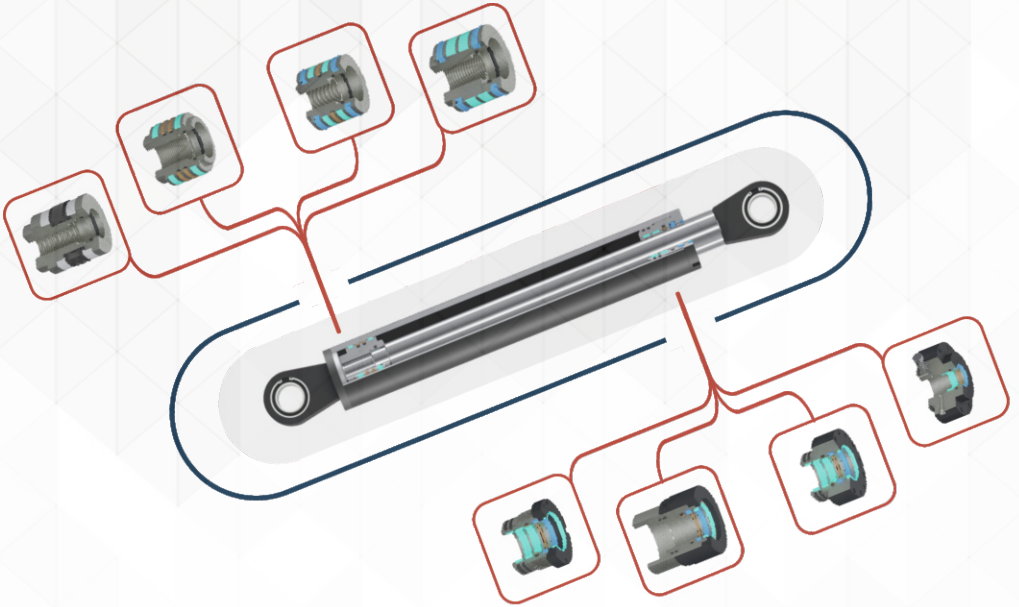

Mounting Options





Industry We Serve

- Infrastructure
- Mining & Earthmoving
- Material Handling
- Industrial Automation
- Defence
- Marine & Offshore
- Renewable Energy
- Metal Processing



Types of Cylinder

"Hydraulics" The word itself having various and wide range of application in which hydraulic cylinders having different types by its application, tonnage & pressure, capacity and Mounting style.

Based On Function

- ▷ Single-acting Cylinder
- ▷ Double-acting Cylinder
- ▷ Differential Cylinder
- ▷ Cushioned Cylinder
- ▷ Position-sensing Cylinder
- ▷ Double ended Cylinder

Based on Construction

- ▷ Tie-Rod Cylinder
- ▷ Welded Cylinder
- ▷ Bolted Cylinder
- ▷ Telescopic Cylinder
- ▷ Mill-type Cylinder



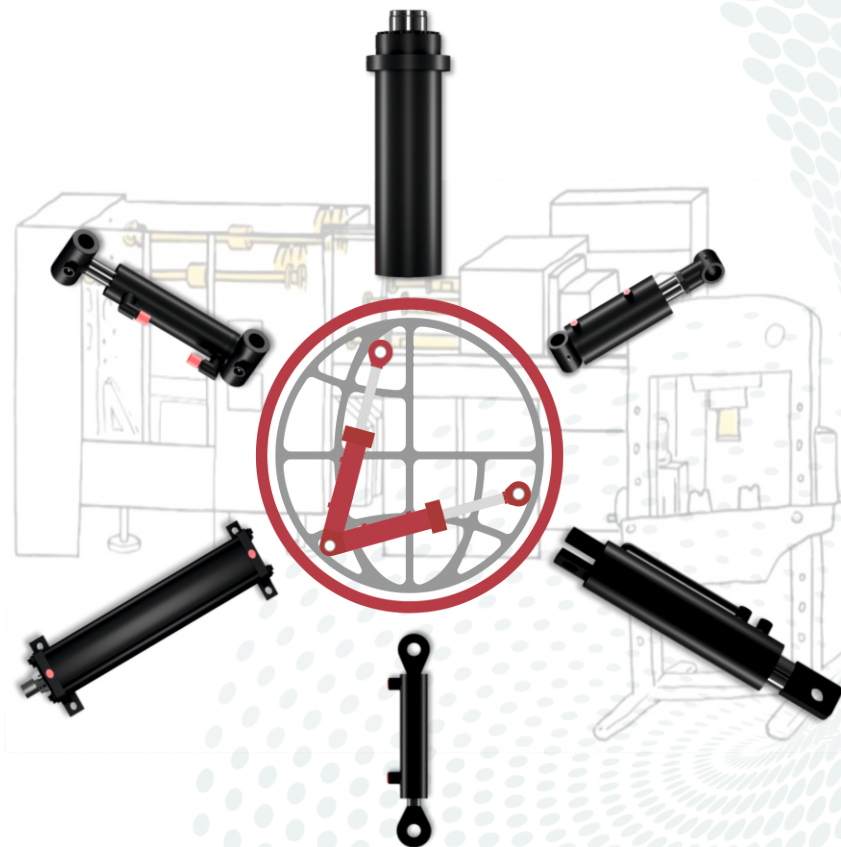

SPM HYDRAULICS PVT. LTD.

Dynamic | Honest | Modern



Domestic inquiry
+91 76988 69989



Global inquiry
+91 76988 69991



sales@spmhydraulics.co.in



info@spmhydraulics.co.in



www.spmhydraulics.co.in



Plot No. 2725, Gate No. 1,
Metoda G.I.D.C., Rajkot -
360021.



follow us on

